



KIT PART NUMBER 3173015
INSTRUCTIONS FOR INSTALLING A HIGH SECURITY CUP KIT FOR MODELS 314,
315, 316, 317, AND 318

CHECK THE PARTS RECEIVED IN THE KIT WITH THE PARTS LIST IN THESE INSTRUCTIONS. IF ANY PARTS ARE MISSING, CONTACT THE NATIONAL VENDORS PARTS DEPARTMENT IMMEDIATELY.

Read these instructions carefully before installing the kit.
Keep these instructions for part numbers and for future reference.

This kit contains the following :

PART NUMBER	DESCRIPTION	QUANTITY
3101144	SCREW - #1/4-20 X .50 HEX. HD. W/LW	2
3141007	BRACKET - LATCH - SHORT	1
3173006	BRACKET ASSEMBLY - CUP MOUNTING - HIGH SECURITY	1
3173009	COLLAR ASSEMBLY - HIGH SECURITY	1
3173010	MOUNTING BRACKET - LATCH - HIGH SECURITY	1
3173013	TURRET ASSEMBLY - CUP - HIGH SECURITY	1
3173014	INSTRUCTIONS	1
4047095	SCREW - #8-32 X .31 PHS T/C W/LW	2



Part I. Modify the cup delivery chute (figure 1):

1. Remove the cup delivery assembly.
2. Using pliers or vice grips, spread the sides of the delivery chute apart approximately .22" per side, for a total width of 4.44".
3. Replace the cup delivery assembly.

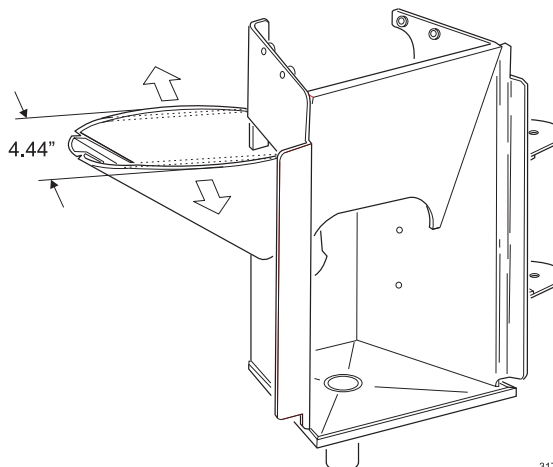

Figure 1

Part II. Install the special turret mounting bracket (figure 2):

1. Remove the part shown by drilling out the spotwelds.
2. Position the high security cup mounting bracket (3173006) directly on top of and in line with the existin turret mounting bracket.

NOTE

There are three large holes and two small holes pre-drilled in the high security cup mounting bracket. Be sure you only use the two small holes in the following step.

3. Using the *two small* mounting holes of the high security cup mounting bracket as a template, drill and tap two holes for 1/4-20 thread.
4. Mount the high security cup mounting bracket (3173006) using two 1/4-20 x .50 hex head screws (3101144).
5. Remove the two existing wire clamps as shown. Keep the attaching screws. Mount them to the latch mounting bracket (3173010) with the same screws previously securing them.
6. Attach the latch bracket (3141007) to the latch mounting bracket (3173010) with two 8-32 x .31" screws (4047095).
7. Mount the latch mounting bracket assembly to the inside of the cabinet as shown, using two 8-32 x .31" screws (4047095).

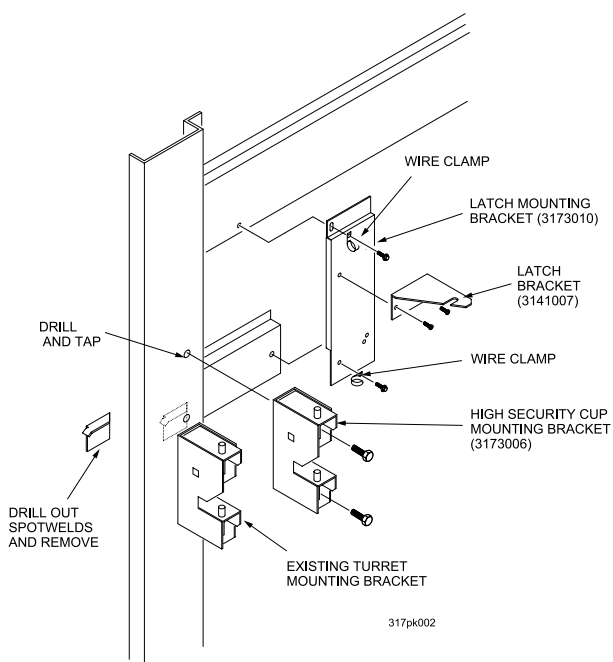

Figure 2



Part III. Install the new cup turret assembly (figure 3):

1. Remove the old cup turret assembly.
2. Remove the mechanism assembly.
3. Remove the old collar assembly from the mechanism assembly and discard.
4. Install the collar assembly (3173009) to the mechanism assembly.
5. Mount the new mechanism assembly to the high security cup mounting bracket previously installed.

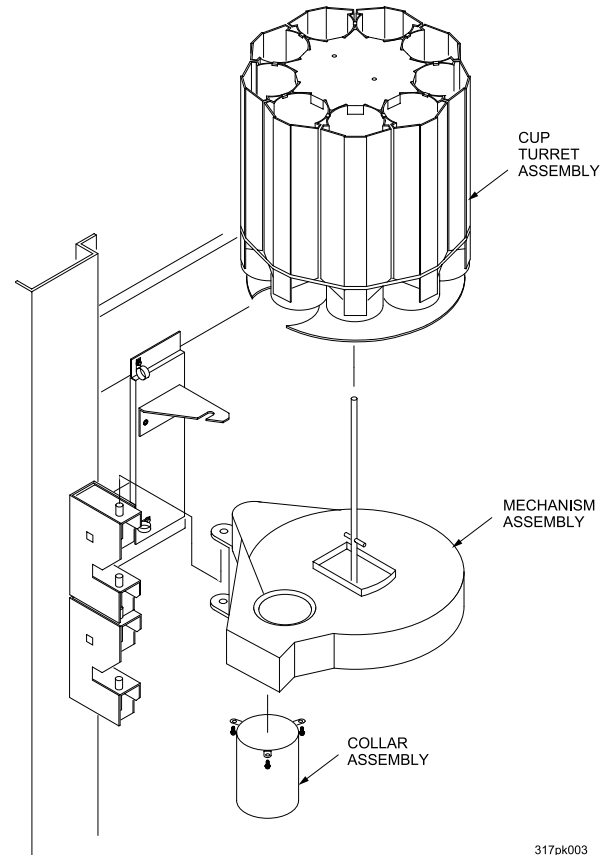

Figure 3

317pk003